



Edition : 3.0  
Date: (10/25)

## Instruction Manual

# ENGINE STAND HES-907F

Order Code: (A340)

1.0 MACHINE DETAILS

MACHINE	ROTATING ENGINE STAND
MODEL NO.	HES-907F
SERIAL NO.	
DATE OF MANF.	

DISTRIBUTED BY



www.machineryhouse.com.au  
www.machineryhouse.co.nz



**NOTE:**  
In order to see the type and model of the machine, please see the specification plate. Usually found on the back of the machine. See example (Fig.1)

---

**PRODUCT SPECIFICATIONS**

Model: HES-907F	Nett Weight: 47kg
Capacity: WLL 907Kg	MFG Date:

Serial No:

---

www.machineryhouse.com.au    www.machineryhouse.co.nz  
Made in China

(Fig.1)

**2.0 SPECIFICATIONS**

These stands accept a wide variety of engines and transmissions. The head swivels 360° with an indexing position lock for accessibility to all parts of the engine. Fully adjustable mounting arms. Swivel castors provide excellent manoeuvrability and also features folding legs for storing.

- Load Capacity .....907kg
- Rotating Head .....360°
- Mounting Centre Height .....815mm
- Nett Weight .....47kg

(Full load capacity rating is also on the specification plate on the engine stand (Fig. 2))



(Fig.2)

### 3.0 SAFETY PRECAUTIONS



**DO NOT** use this machine unless you have been instructed in its safe use and operation and have read and understood this manual. It is the responsibility of the owner to make sure all personnel read this manual prior to using the device. It is also the responsibility of the device owner to keep this manual intact and in a convenient location for all to see and read. If the manual or product labels are lost or not legible, they need to be replaced before operating.

#### **THE NATURE OF HAZARDOUS SITUATIONS WARNING!**

The use of portable automotive lifting and support device is subject to certain hazards that cannot be prevented by mechanical means, but only by the exercise of intelligence, care, and common sense. It is therefore essential to have owners and personnel involved in the use and operation of the equipment who are careful, competent, trained, and qualified in the safe the operation of the equipment and its proper use. Examples of hazards are dropping, tipping or slipping of loads caused primarily by improperly securing loads, overloading, off-centered loads, use on other than hard level surfaces, and using equipment for a purpose for which it was not designed.

#### **METHODS TO AVOID HAZARDOUS SITUATIONS WARNING!**

- Read, study, understand and follow all instructions before operating this device.
- User and bystanders must wear eye protection that meets the Australian and New Zealand standards.
- Inspect the engine stand before each use. Do not use if damaged, altered, modified, in poor condition, or has loose or missing hardware or components. Take corrective action before using the engine stand.
- Do not use beyond the rated capacity.
- Use only on hard level surface capable of supporting the load.
- Make sure all mounting hardware is securely tightened and setup is stable before rotating the engine.
- Always use high strength SAE grade 8 bolts for mounting engine to mounting fingers.
- Make sure that the widest set of mounting fingers are nearest the ground when mounting engine to the stand.
- Ensure the load is centered, balanced and secured to the mounting head and fingers. The engine's weight should be balanced within 25mm of the mounting head's rotational axis.
- Adequately support the vehicle before starting repairs.
- Never loosen mounting head bolts or engine mounting bolts unless engine is supported by a crane or hoist.
- Only attachments and/or adapters supplied by the manufacturer should be used.
- Do not use the stand to dolly or transport engine.
- Do not crawl under engine or place any part of your body under engine at any time.
- Refer to engine manufacturer's service manual for proper lifting points, mounting points and bolt sizes. Mounting bolts should be torqued at appropriate amount to maintain load.

#### **CONSEQUENCES OF NOT AVOIDING HAZARDOUS SITUATIONS WARNING!**

Failure to read this manual completely and thoroughly, failure to understand its OPERATING INSTRUCTIONS, SAFETY WARNINGS, MAINTENANCE INSTRUCTIONS and comply with them, could cause accidents resulting in serious or fatal personal injury and/or property damage.



#### **ENVIRONMENT PROTECTION**

Recycle unwanted materials instead of disposing of them as waste. All tools, accessories and packaging should be sorted, taken to a recycling centre and disposed of in a manner which is compatible with the environment. When the product becomes completely unserviceable and requires disposal, drain any fluids (if applicable) into approved containers and dispose of the product and fluids according to local regulations.

### 4.0 OPERATING INSTRUCTIONS

**SETUP INSTRUCTIONS** *This safety warning is used for the SETUP INSTRUCTIONS section of this manual to alert you to potential personal injury hazards. Obey all instructions to avoid possible injury or death.*



- Consult the vehicle or engine manufacturers service manual or technical bulletins that provide information on suggested engine mounting tips, proper size bolts and the engine's center of balance. The engine's center of balance must be aligned with the rotational axis of the engine stand's mounting head assembly.
- Drain oil and coolant and remove clutch bell housing and flywheel from the engine before mounting. Attach a lifting bar or sling to the engine and secure to a shop crane or hoist. Slowly lift the engine from its compartment making sure no other components, wires or hoses obstruct the free movement of the engine. Raise the engine high enough so its center of balance is close to the rotational axis of the stand's mounting head.
- Make sure, the four mounting fingers are loosely connected to the mounting head plate. Secure the four mounting fingers to the bell housing end of the engine with the appropriate bolts and washers. Reposition the mounting, fingers and engine so the engine's center of balance is within 25mm of the mounting head's rotational axis. Tighten all bolts to a sufficient torque requirement that prevents any slippage.
- Slowly lower the crane or hoist so the engine stand supports full weight of the engine. Check engine balance and secure setup of the engine to the stand by slowly rotating the engine with the indexing position handle. If balance or setup are not stable, rotate the engine to its original position, raise the crane or hoist so the weight of the engine is taken by the hoist and make the correct adjustments. After adjustments are made, tighten all bolts. This adjustment procedure may need to be performed several times until correct. After the setup is balanced and secure, the lifting bar or sling can be removed from crane or hoist.
- To remove the engine from the stand, connect the lifting bar or sling to the crane or hoist and raise the engine high enough to take the weight off the stand. Carefully remove the bolts that connect the four mounting fingers to the engine. Be aware there will be a slight movement as the total engine weight is transferred to crane or hoist.
- This engine stand has a folding feature that can save space and make storage easy. Remove the pins so the 2 feet can be folded up vertically. The pins and clips can be stored in the open holes.

### PREVENTATIVE MAINTENANCE

1. Always store the engine stand in a well protected area where it will not be exposed to inclement weather, corrosive vapors, abrasive dust, or any other harmful elements. The engine stand must be cleaned of water, snow, sand, grit, oil, grease or other foreign matter before using.
2. Lubricate the wheels, casters, fittings and rotating shaft with a general purpose grease.
3. Every engine stand owner is responsible for keeping the engine stand label clean and readable. Use a mild soap solution to wash the external surfaces of the stand.
4. Inspect the stand before each use. Do not use the stand if any component is cracked, broken or bent. Do not use the stand if it has loose or missing hardware or components, or is modified in any way. Take corrective action before using the stand again.

# 5.0 PARTS LIST - DIAGRAM

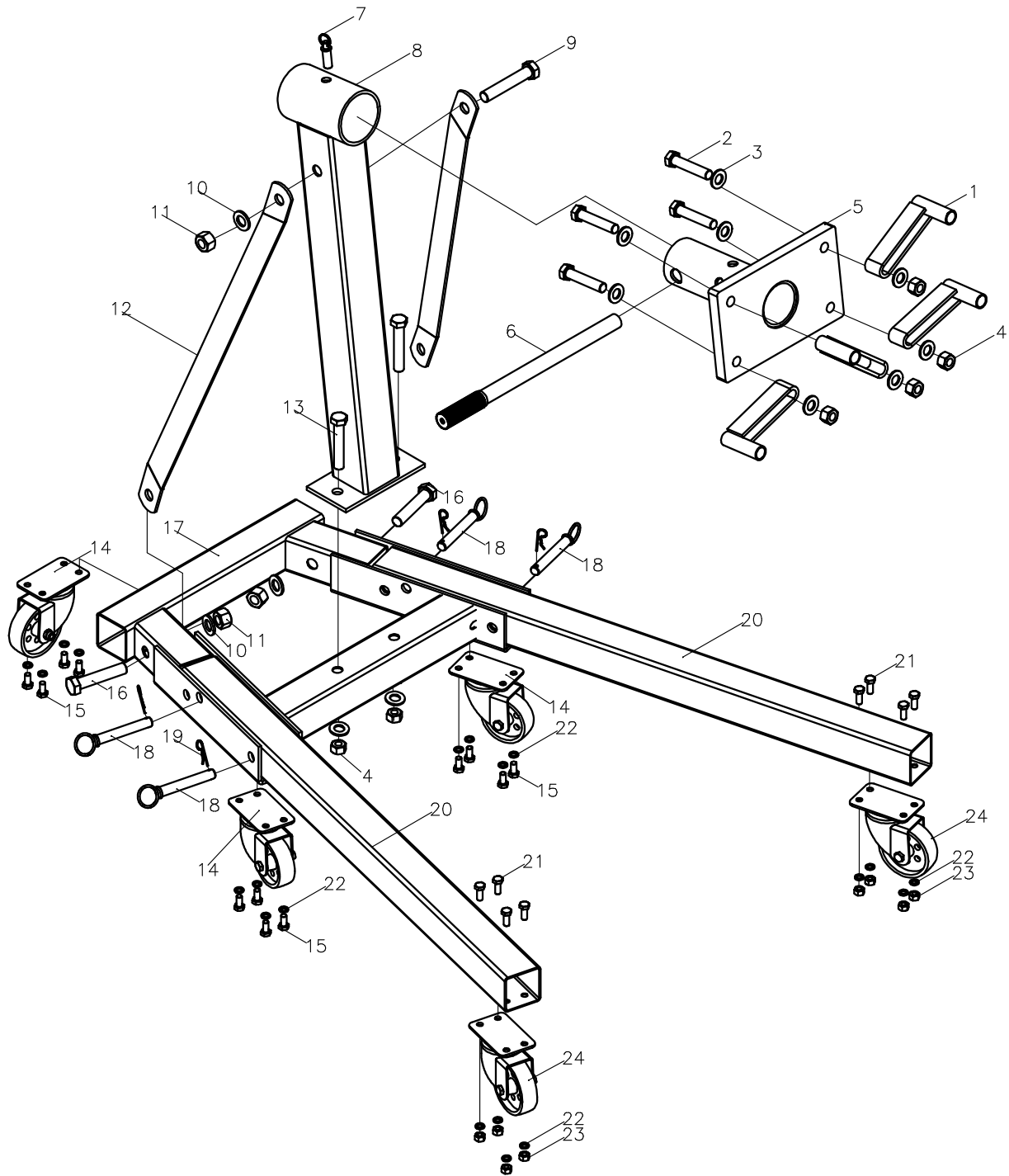

Part No.	Description	Qty
1	Shifting Stand	4
2	Bolt M14x65mm	4
3	Washer 14mm	10
4	Nut M14	6
5	Turning Plate	1
6	Handle	1
7	Pin	1
8	Main Post	1

Part No.	Description	Qty
9	Bolt M16x100mm	1
10	Washer 16mm	3
11	Nut M16	3
12	Support	2
13	Bolt M14x85mm	2
14	3.5" Caster	3
15	Bolt M8x12mm	12
16	Bolt M16x90mm	2

Part No.	Description	Qty
17	Base Frame	1
18	Locking Pin	4
19	R-Pin	4
20	Leg	2
21	Bolt M8x20mm	8
22	Spring Washer 8mm	20
23	Nut M8	8
24	3" Caster	2

**6.0 ASSEMBLY INSTRUCTIONS****6.0**

Attach three 3.5" casters (#14) to the bottom of the base frame (#17) using M8x12mm bolts (#15) and spring washers (#22) as shown.

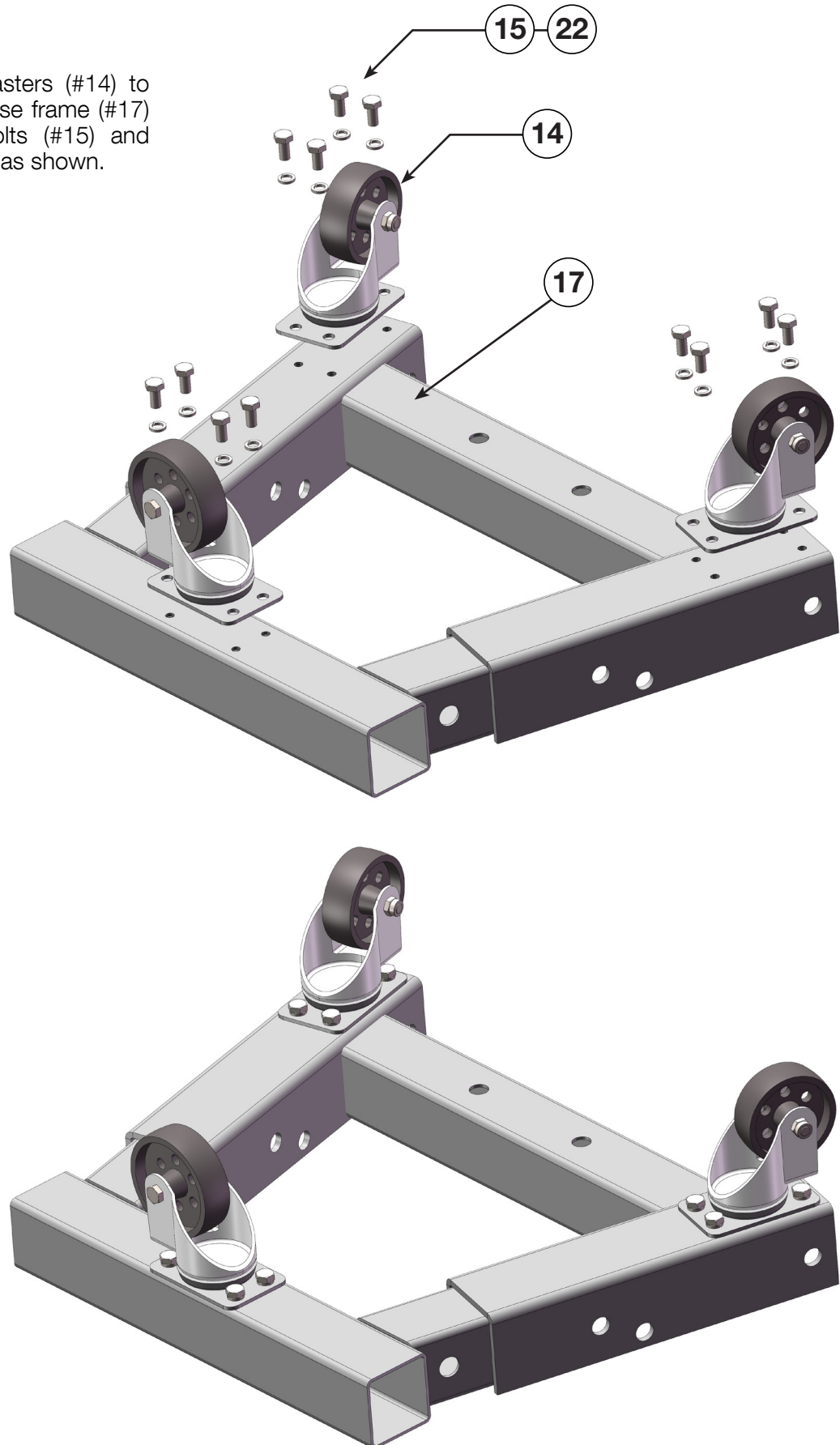

**6.0 ASSEMBLY INSTRUCTIONS****6.1**

Attach a 3" caster wheel (#24) to the bottom of each leg (#20) using bolts M8x20mm (#21), nuts M8 (#23) and spring washers 8mm (#22) as shown.

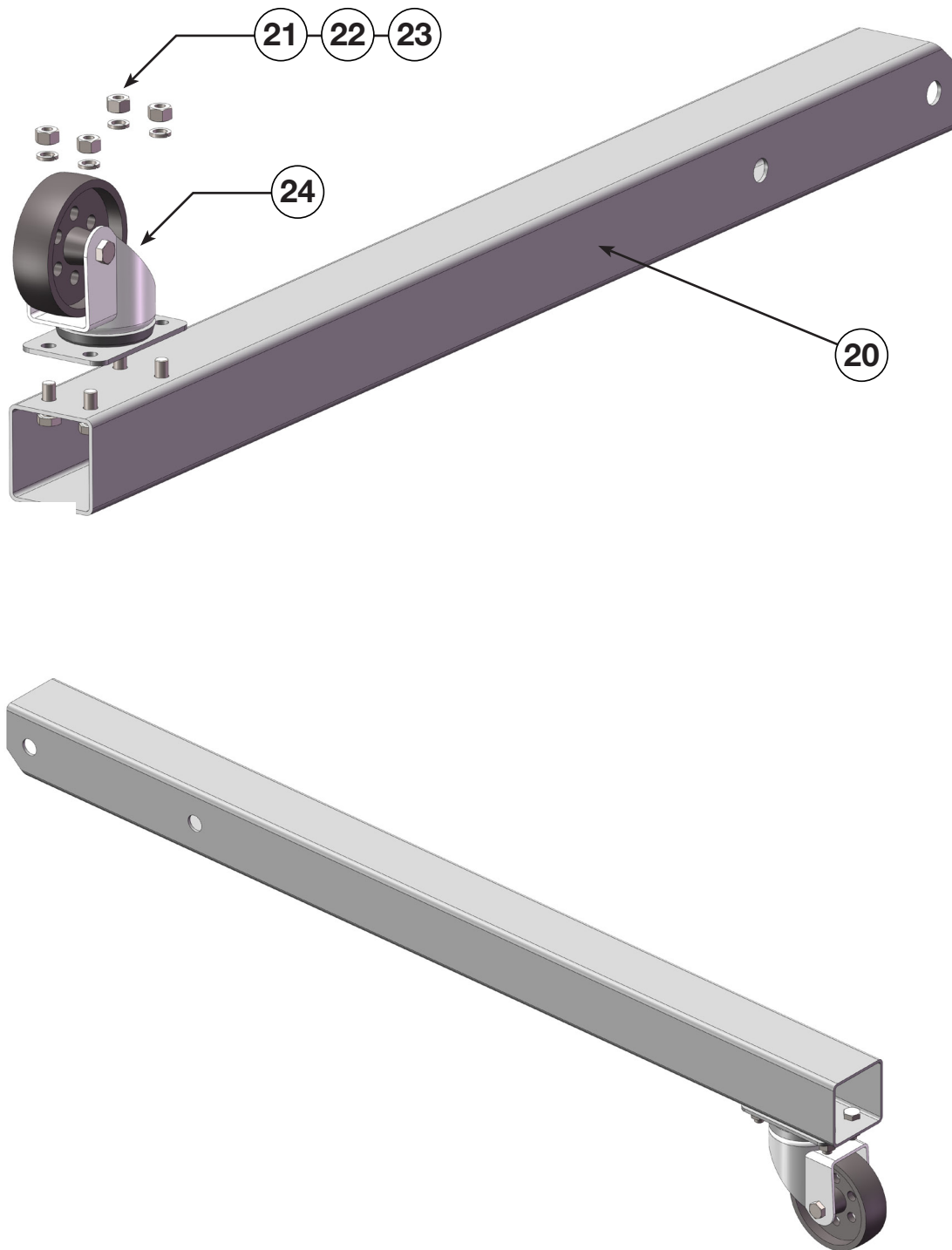

**6.0 ASSEMBLY INSTRUCTIONS****6.2**

Slide the two legs (#20) into the base frame (#17) and insert four locking pins (#18) with four R-Pins (#19) to secure the legs to the base frame as shown.

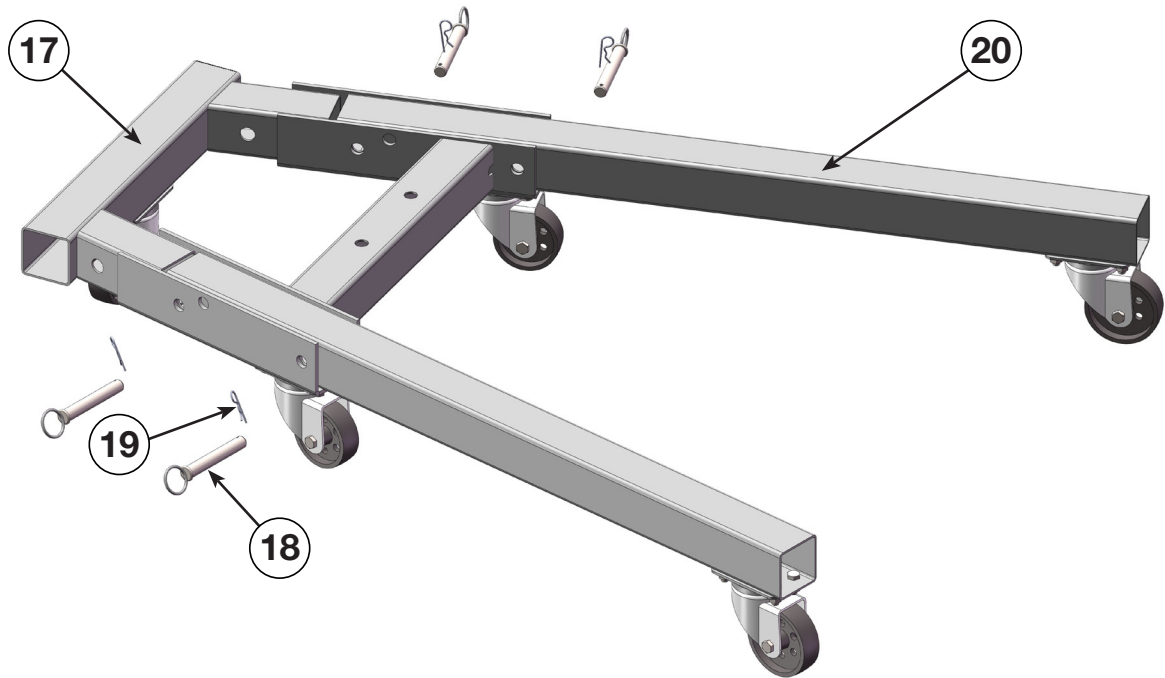

**6.0 ASSEMBLY INSTRUCTIONS****6.3**

Attach the main post (#8) to the base frame (#17) using bolts M14x85mm (#13), nuts M14 (#4) and washers 14mm (#3) as shown.

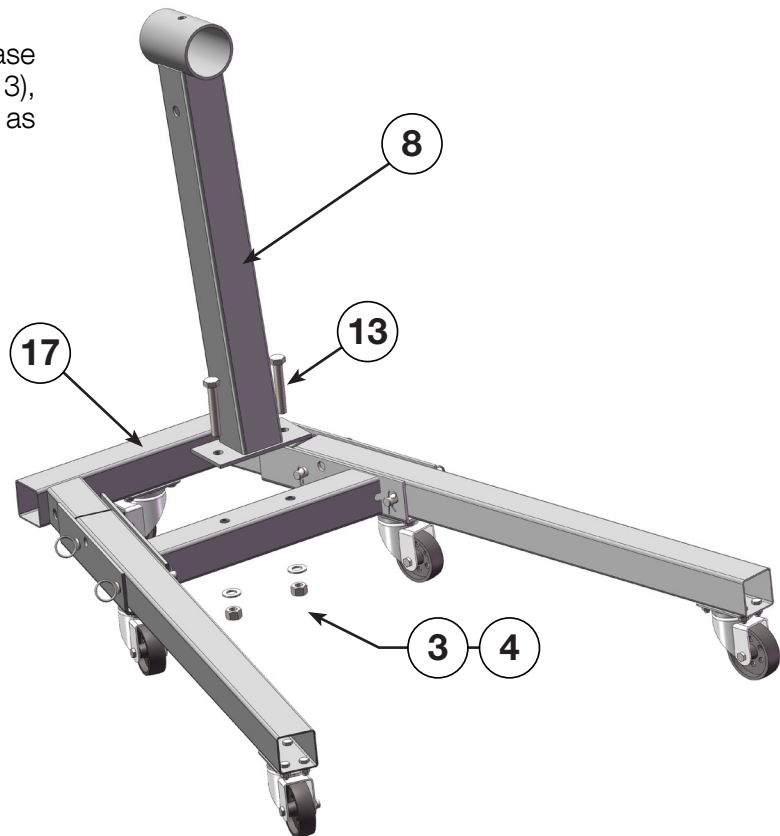

**6.4**

Attached the two supports (#12) to the main post (#8) and the base frame (#17) using bolts (#9), nuts M16 (#11) and washers (#10) as shown.



**6.5**

Assemble the turning plate (#5) and the four shifting stands (#1) together using bolts M14x65mm (#2), nuts M14 (#4) and washers 14mm (#3) as shown.

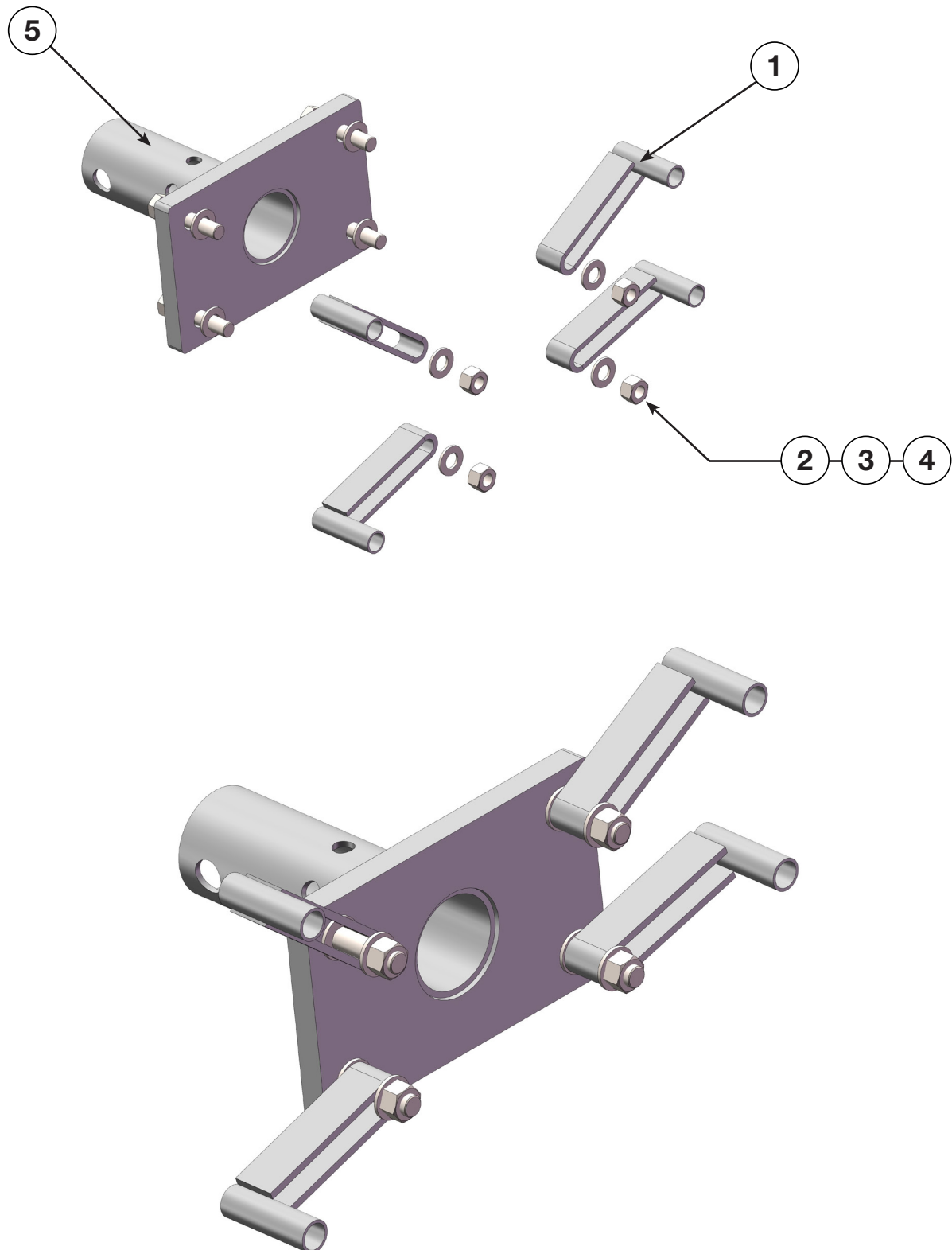

**6.0 ASSEMBLY INSTRUCTIONS****6.6**

Slide the turning plate (#5) into the top of the main post (#8) as shown and locate and line up the holes to insert the pin (#7).



**6.7**

Insert the crank handle (#6) as shown ready for use.



## 7.0 STORING INSTRUCTIONS

### 7.0

To fold up legs - release the R-pin (#19) from one leg and remove locking pin (#18) from hole (a). Fold leg up while supporting and insert locking pin (#18) into hole (b), then insert R-pin (19). Repeat this process for the other leg. The engine stand is now ready for storing.

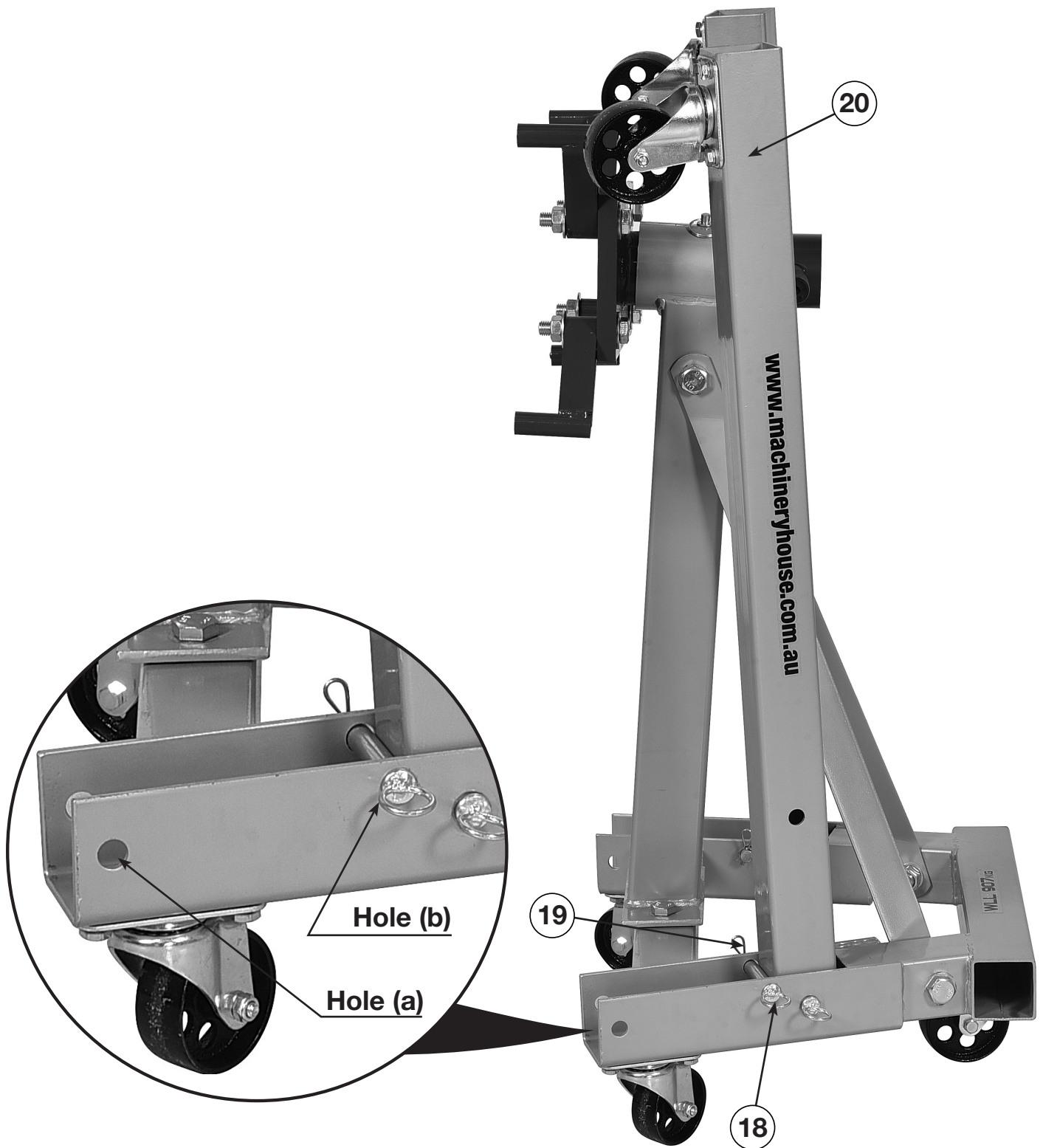



# General Machinery Safety Instructions

---

Machinery House  
requires you to read this entire Manual before using this machine.

- 1. Read the entire Manual before starting machinery.** Machinery may cause serious injury if not correctly used.
- 2. Always use correct hearing protection when operating machinery.** Machinery noise may cause permanent hearing damage.
- 3. Machinery must never be used when tired, or under the influence of drugs or alcohol.** When running machinery you must be alert at all times.
- 4. Wear correct Clothing.** At all times remove all loose clothing, necklaces, rings, jewelry, etc. Long hair must be contained in a hair net. Non-slip protective footwear must be worn.
- 5. Always wear correct respirators around fumes or dust when operating machinery.** Machinery fumes & dust can cause serious respiratory illness. Dust extractors must be used where applicable.
- 6. Always wear correct safety glasses.** When machining you must use the correct eye protection to prevent injuring your eyes.
- 7. Keep work clean and make sure you have good lighting.** Cluttered and dark shadows may cause accidents.
- 8. Personnel must be properly trained or well supervised when operating machinery.** Make sure you have clear and safe understanding of the machine you are operating.
- 9. Keep children and visitors away.** Make sure children and visitors are at a safe distance for your work area.
- 10. Keep your workshop childproof.** Use padlocks, Turn off master power switches and remove start switch keys.
- 11. Never leave machine unattended.** Turn power off and wait till machine has come to a complete stop before leaving the machine unattended.
- 12. Make a safe working environment.** Do not use machine in a damp, wet area, or where flammable or noxious fumes may exist.
- 13. Disconnect main power before service machine.** Make sure power switch is in the off position before re-connecting.
- 14. Use the Correct Extension Lead.** Extension leads should be avoided where possible but if required, always use an extension lead that is rated for the power requirements of your machinery. Using an incorrectly rated extension lead can lead to overheating, damage to machinery, or potential fire hazards. Ensure leads are in good condition and free of damage. Replace if faulty.
- 15. Keep machine well maintained.** Keep blades sharp and clean for best and safest performance. Follow instructions when lubricating and changing accessories.
- 16. Keep machine well guarded.** Make sure guards on machine are in place and are all working correctly.
- 17. Do not overreach.** Keep proper footing and balance at all times.
- 18. Secure workpiece.** Use clamps or a vice to hold the workpiece where practical. Keeping the workpiece secure will free up your hand to operate the machine and will protect hand from injury.
- 19. Check machine over before operating.** Check machine for damaged parts, loose bolts, Keys and wrenches left on machine and any other conditions that may effect the machines operation. Repair and replace damaged parts.
- 20. Use recommended accessories.** Refer to instruction manual or ask correct service officer when using accessories. The use of improper accessories may cause the risk of injury.
- 21. Do not force machinery.** Work at the speed and capacity at which the machine or accessory was designed.
- 22. Use correct lifting practice.** Always use the correct lifting methods when using machinery. Incorrect lifting methods can cause serious injury.
- 23. Lock mobile bases.** Make sure any mobile bases are locked before using machine.
- 24. Allergic reactions.** Certain metal shavings and cutting fluids may cause an allergic reaction in people and animals, especially when cutting as the fumes can be inhaled. Make sure you know what type of metal and cutting fluid you will be exposed to and how to avoid contamination.
- 25. Call for help.** If at any time you experience difficulties, stop the machine and call your nearest branch service department for help.



# Engine Stand Safety Instructions

---

---

Machinery House  
requires you to read this entire Manual before using this machine.

- 1. Engine Stand Loading Requirement.** Refer to your vehicle service manual to locate the safe engine lifting/support locations, and to verify that the engine weight does not exceed the maximum engine stand load rating.
- 2. Engine Stand Condition.** Engine Stand must be maintained for a proper working condition. Never operate a Engine Stand that has damaged or worn parts. Scheduled routine maintenance should be performed on a scheduled basis. Check the stand, bolts, framework, welds and wheels for cracks or damage. Replace if necessary.
- 3. Crushing Hazard.** Never place any part of your body under the Engine Stand, or under a lifted load. Always mount all four mounting arms at the appropriate points on the engine. All mounting arms must be bolted tight against the engine. Never roll the stand without the lock pin installed. Otherwise serious injury can occur.
- 4. Work area hazards.** Pay attention to other persons in the area and know what is going on around the area to ensure unintended accidents.
- 5. Overloading Engine Stand.** Do not over load the Engine Stands capacity. Always check the weight of the engine before using this Engine Stand.
- 6. Warning Labels.** Take note of any warning labels on the Engine Stand and do not remove them.
- 7. Rotating Engine.** Before removing the lock pin to rotate the engine, fully support the engine so the engine will not uncontrollably rotate when the pin is removed.
- 8. Level Surface.** Only use this engine stand on a hard level surface capable of sustaining the combined load.
- 9. Other Hazards.** Never attempt to start or run an engine on this engine stand. Never allow children to play on Engine Stand while in use or in storage.
- 10. Call for help.** If at any time you experience difficulties, stop and call you nearest branch service department for help.

# PLANT SAFETY PROGRAM

## **NEW MACHINERY HAZARD IDENTIFICATION, ASSESSMENT & CONTROL**

### **Engine Stand**

Developed in Co-operation Between A.W.I.S.A and Australia Chamber of Manufactures  
 This program is based upon the Safe Work Australia, Code of Practice - Managing Risks of Plant in the Workplace ( WHSA 2011 No10 )

Item No.	Hazard Identification	Hazard Assessment	Risk Control Strategies <small>(Recommended for Purchase / Buyer / User)</small>
B	CRUSHING	HIGH	Ensure engine stand is on level solid ground. Ensure engine is correctly mounted and secured tight. Keep body parts clear from under engine when mounting. Do not exceed maximum capacity of engine stand. Wear safety boots
J	SLIPPING, TRIPPING, & FALLING	LOW	Avoid uneven or slippery surfaces when moving engine stand under load.
Plant Safety Program to be read in conjunction with manufactures instructions			



[www.machineryhouse.com.au](http://www.machineryhouse.com.au)



[www.machineryhouse.co.nz](http://www.machineryhouse.co.nz)

Authorised and signed by:

Safety officer:

Manager:

Revised Date: 2nd June 2025



---

**Note:** It is our policy to continually improve products and as such we reserve the right to alter data, specifications and component parts without prior notice.

**Important:** No Liability is accepted for incorrect use of this product.

**Warranty:** Guarantee is 12 months from purchase date, proof of which is required for any claim.

DISTRIBUTED BY



[www.machineryhouse.com.au](http://www.machineryhouse.com.au)

[www.machineryhouse.co.nz](http://www.machineryhouse.co.nz)